

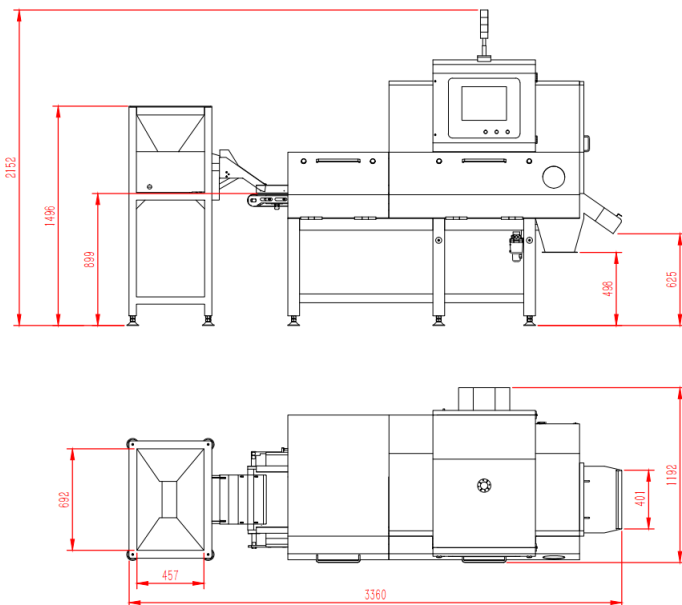

Bulk Products X-ray Inspection System Machine components:
Vibration device + X-ray inspection system+ air jet rejecter system

Dimensions



General specifications

PHYSICAL SPECIFICATIONS

Best Inspection Ability	0.1mm(SUS304 ball) 0.04*2mm(SUS wire) 0.6 mm (Glass Ball) 0.6 mm(Ceramic)
Estimated Sensitivity with Product	0.3mm(SUS304 ball) 0.04*5mm(SUS wire) 0.8 mm (Glass Ball) 0.8 mm(Ceramic) 1 mm (bone, gravel, plastic) Common impurities: 0.04mm metal wire in scrubbing, buttons, cigarette butts, plastic ties, insects (high density), wooden sticks, bamboo toothpicks, plastic toothpicks, rubber, gravel... (size depends on product)
Application	-Detecting impurities before packaging for factories producing pepper, cashew, beans, almonds, macadamia nuts, frozen fruits, etc. -AI technology automatically detects and removes defective, shriveled, or hollow kernels in macadamias, almonds, walnuts, etc. -Detects and removes dead, hollow, or sand-filled clams and mussels from the conveyor belt at high throughput rates.
X-ray tube	MAX.350W/80Kv (Beryllium Window)
Max Detecting Height	100mm
Max Detecting Width	400mm
Estimated Capacity (Max)	1.5-3 tons per hour
Conveyor Height	900+100mm (other height is optional)
Working Direction	From left to right
Screen	Full-color TFT 15" Touch Screen
O/S	Windows 7 & Real-Time System
Connectivity	LAN port, USB port
Product Management	Complete product log
Parameter Adjustment	Auto learning/Manual setting
Image Management	Auto image save/print/analyses
Power Supply	220V, AC, 50/60Hz
Body Material	SUS304
Purification	Easy to wash
Cooling method	Air conditioned cooling
Operation temperature	0-40°C
Operation humidity	30-90%
X-ray emissions	< 1microsievert per hour
X-ray protection	Lead/Lead-free protective curtain
Rejector	48 tunnel air jet rejector

Conveyor Parameter

Speed	10-160 m/min
Width	420mm
Max Height	100mm
Max Load	25kg

